

# PIG Modular IBC Spill Containment Pallet

## Instructions for Expansion Tank – PAKE130, PAKE131, PAKE132 and PAKE133

**Step 1** Place pallets (1) and/or expansion tanks (2) in desired configuration and locate two drill points on each mating sidewall of pallet (1) and/or expansion tank (2).

**NOTE:** Drill point dimples are located 2½" from bottom and are 18" apart.

**Step 2** Using the 2⅜" hole saw (4B), place drill bit of hole saw in center of drill point and cut hole through the sidewall. Repeat for remaining drill points.

**CAUTION:** Only cut holes in sidewalls that are intended to have bulkhead fitting (3).

**Step 3** Remove grates from pallet (1) or open lid of the expansion tank (2) to access backside of hole. From inside, insert 2¼" bulkhead fitting (3A) through hole. Place two gaskets (3B) onto inserted bulkhead fitting (3A) before passing bulkhead fitting (3A) through hole in mating sidewall.

**NOTE:** Gaskets (3B) should be between mating sidewalls.

**Step 4** Start left hand threaded hex nut (3C) onto bulkhead fitting (3A). Do not tighten. Side of hex nut (3C) with word "tighten" and directional arrow should be facing away from bulkhead fitting (3A) when attaching hex nut (3C) to bulkhead fitting (3A). Repeat for remaining bulkheads.

**Step 5** Tighten bulkhead fittings (3A) using two ⅜" drive ratchets (not provided) along with drive socket wrench (4C) and lug spanner wrench (4A).

**NOTE:** Lug spanner wrench (4A) is designed to fit over lugs on round side of bulk head fitting (3A). Tighten bulkhead fitting (3A) until mating sidewalls are pulled together and gaskets (3B) are slightly compressed. Repeat for remaining bulkheads.

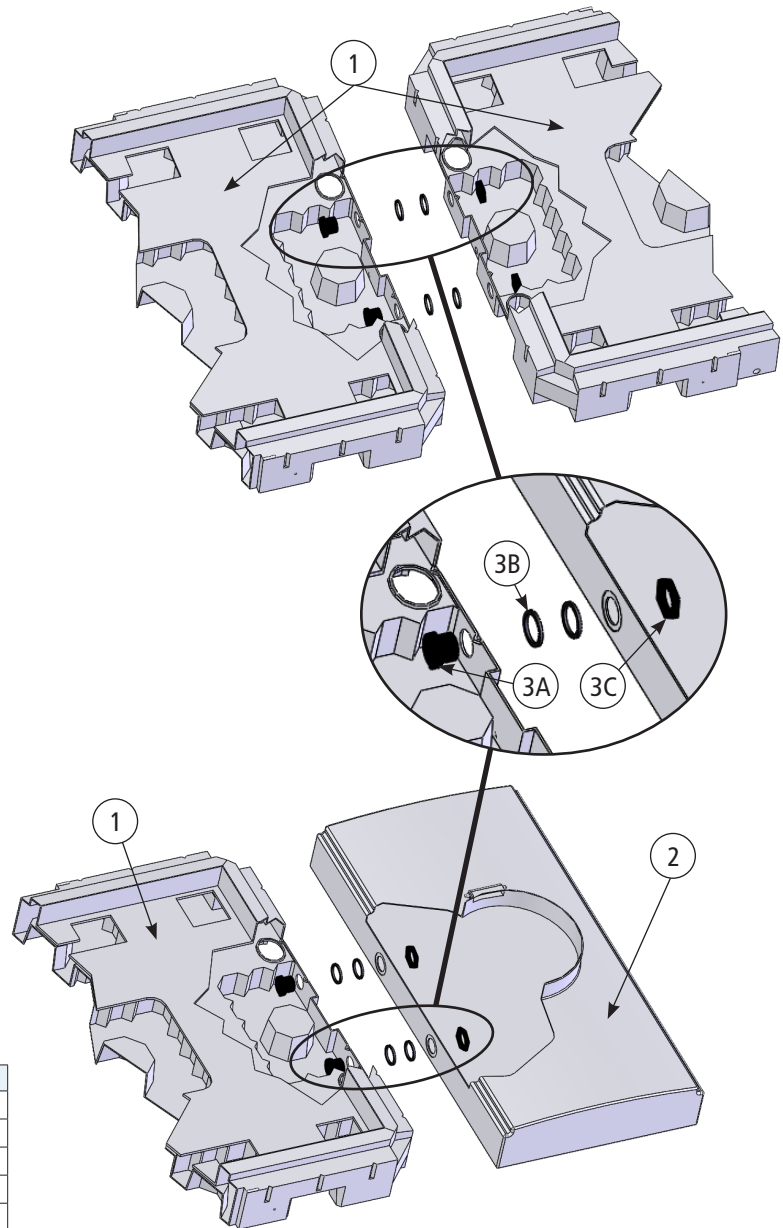

**NOTES:** All plug assemblies should be tight before putting product in use. Wrench and hole saw kit provided; portable drill and (2) ⅜" drive ratchets not provided.

Item #	Part #	Description	PAK119	PAK120	PAK121	PAK122
1	PAK672	Black 4-drum Pallet without Drain	2	3	4	5
2	PAK116	Black 65-gallon Expansion Tank	2	2	1	0
3	PAK118	2 ¼" Bulkhead Fitting Assembly	3	4	4	4
3A		Bulkhead Fitting (2 per pack)				
3B		Gasket (4 per pack)				
3C		Hex Nut (2 per pack)				
4	PAK117	Wrench and Hole Saw Kit	1	1	1	1
4A		⅜" Drive Lug Spanner Wrench				
4B		2 ⅜" Hole Saw with Arbor				
4C		⅜" Drive Socket Wrench				



**New Pig**

One Pork Avenue  
Tipton, PA 16684-0304

**newpig.com**

North America: **1-800-468-4647**

Europe: **+31 (0)76 596 92 50**

China: **+86-21-400 921 5178**

PIG, PIG logo are registered trademarks in USA and other countries. See [tm.newpig.com](http://tm.newpig.com)

UK: **0800 919 900**

Outside North America: **+1-814-684-0101**

502472 / 352338